

PART NO. SEE CHART
 ENG. NO. SD-8993-(****)*

NOTES:

1. CRIMP FOR 18-24 AWG WIRE (2.79)/.11 MAX INSUL DIA
2. CODE LETTER PRECEDING PART No. DESIGNATES MFG LOC'N I=IRELAND
3. MATERIAL: (0.25)/.010 THICK BRASS
4. THIS PART CONFORMS TO MOLEX PROD. SPEC. 99020-0087

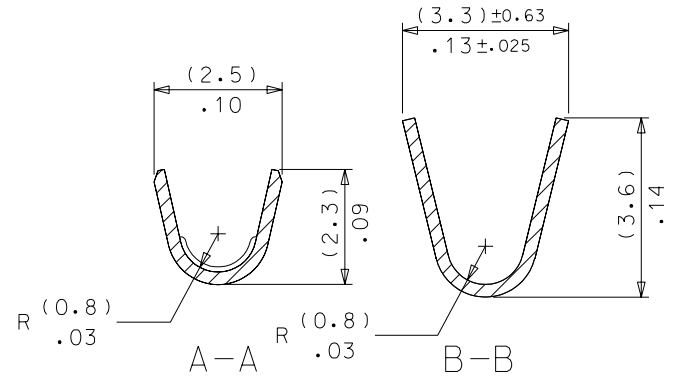
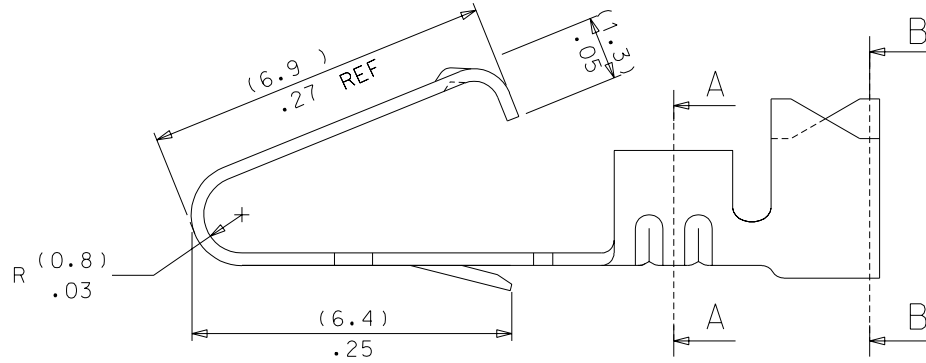
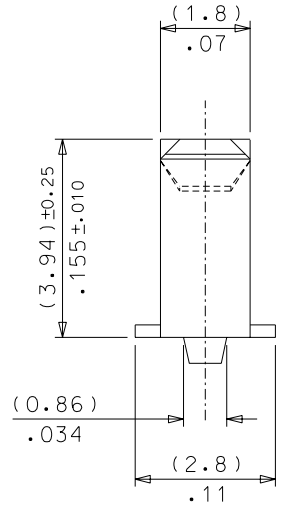
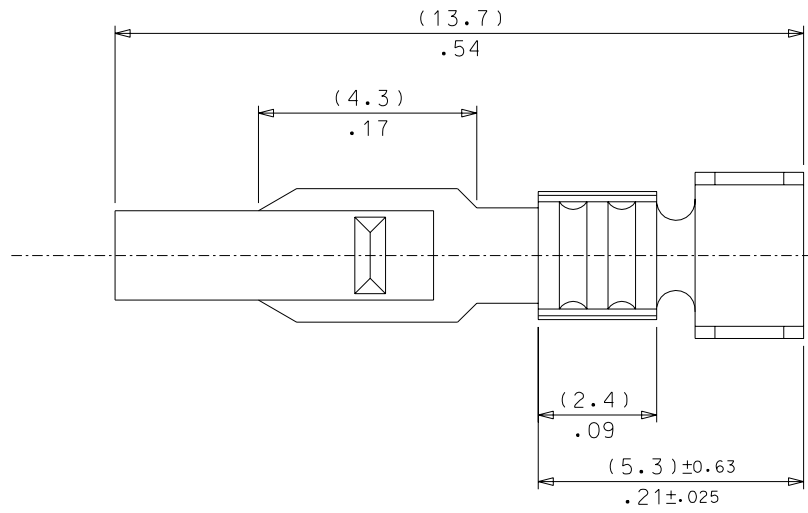

PART No.	ENG No.	FORM	FINISH
08-50-0011	8993-(P125)	CHAIN	(P125) HOT TIN DIP
NOT TOOLED	8993-(P125)L	LOOSE	.000100/.000250 (PRE PLATE)
I 08-50-0277	8993-(P902)	CHAIN	(P902) HOT TIN DIP
I 08-50-0276	8993-(P902)L	LOOSE	.000040/.000100 FOR INT'L USE ONLY (PRE PLATE)

CHANGED PLATING CODES
 EC NO. E2004-0036
 DRWN: PSHEAHAN 03/07/14
 CHK: / / / /
 APPR: / / / /

QUALITY SYMBOLS
 MAJOR =
 CRITICAL =

GENERAL TOLERANCES: (UNLESS SPECIFIED)

	mm	INCH
4 PLACES	±0.	±.
3 PLACES	±0.	±.010
2 PLACES	±0.20	±.014
1 PLACE	±0.30	±.

ANGULAR: ± 1/2°

DRAFT WHERE APPLICABLE MUST REMAIN WITHIN DIMENSIONS

SCALE 10:1
 DESIGN UNITS mm INCH
 THIRD ANGLE PROJECTION mm INCH mm ONLY INCH ONLY
 DRAWN BY & DATE T.MAHON 98/10/26
 CHECKED BY & DATE M.GOONEY / /
 APPROVED BY & DATE MWILHITE / /

TITLE: TERMINAL, CRIMP STYLE

MOLEX INCORPORATED

CAD FILENAME S8993X1.DGN MATERIAL NO. SEE CHART DRAWING NO. SD-8993-**** SHEET NO. 1 OF 1

THIS DRAWING CONTAINS INFORMATION THAT IS PROPRIETARY TO MOLEX INCORPORATED AND SHOULD NOT BE USED WITHOUT WRITTEN PERMISSION.